

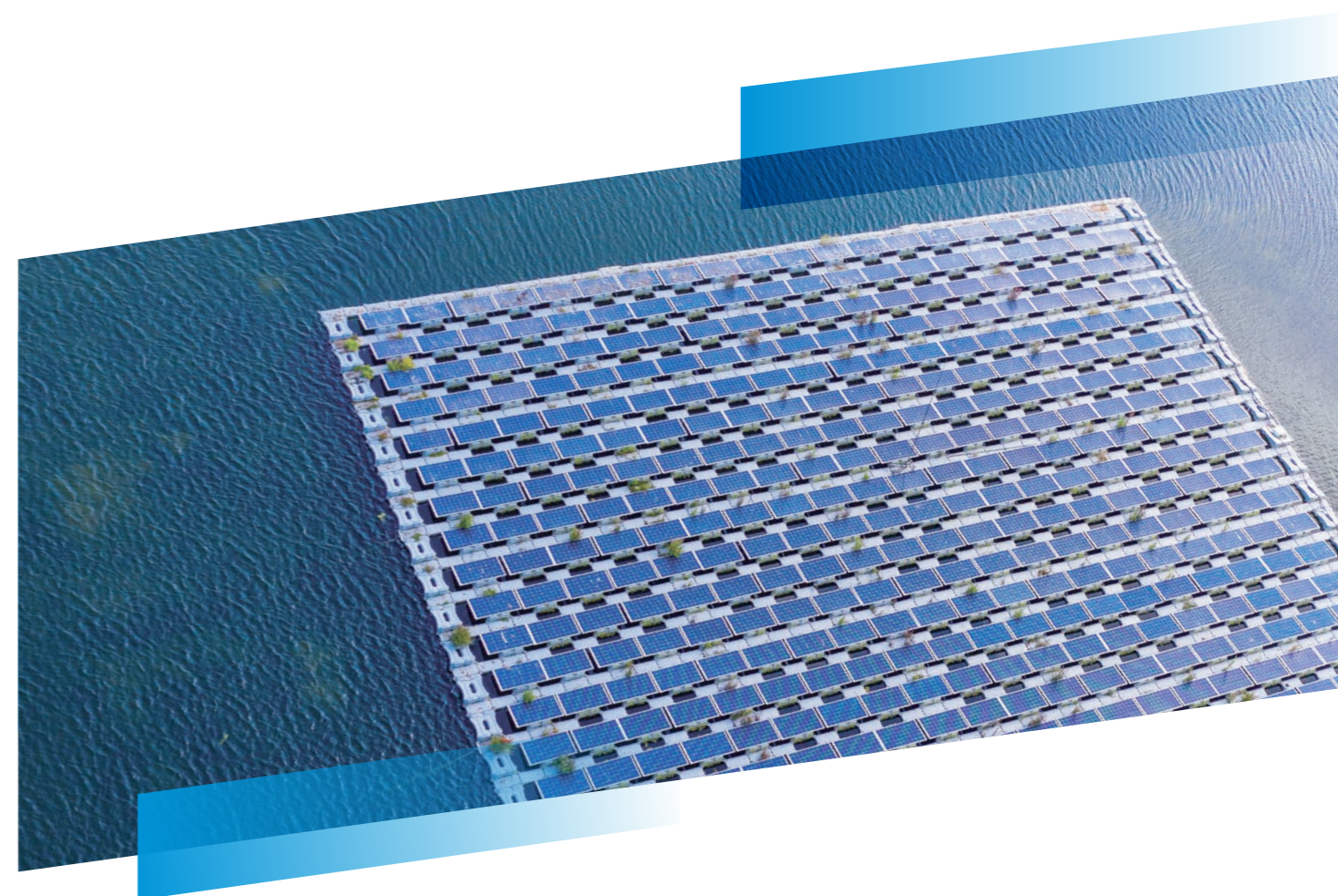

Trinasolar

Trinasolar  
天合光能



# Trina solar Offshore PV Module White Paper

# Offshore PV Module White Paper

## Foreword

---

As a new application scenario, Offshore PV will face severe marine environment challenges, such as high temperature, high humidity, Salt spray corrosion, gale, wave, precipitation. The modules need to have higher reliability. This white paper aims to provide the matters to be noted during the usage of PV modules in coastal regions and offshore for the reference by the application clients of PV systems.

# Content

<b>1. Background and main forms of application of offshore photovoltaics</b>	01
1.1 Offshore PV in China	01
1.2 Offshore PV in other regions	01
<b>2. Offshore PV classification and current challenges</b>	01
2.1 Classification of offshore photovoltaics	01
2.2 Main environmental challenges and failures of offshore PV	02
<b>3. Offshore photovoltaic module solutions</b>	03
3.1 Module Solutions	03
3.2 Offshore PV Module Certification	05
3.3 Trina's 700W + offshore solution	05
3.4 Coastal and Offshore Considerations for Offshore PV Modules	06
3.4.1 Bird droppings	06
3.4.2 Wave dissipation	07
<b>4. Trina Solar's reliability enhancement tests of Offshore PV module</b>	07
4.1 Mechanical loads	07
4.2 High temperature and humidity	09
4.3 Salt-spray corrosion	10
<b>5. Trina Solar offshore PV case</b>	13
<b>6. Trends and Prospects of Offshore PV</b>	14

# 01

## Background and Offshore PV classification

In recent years, with the continuous growth of land-based PV installations, land resources are becoming a key factor restricting the development of PV on a large scale. While the ocean is vast and unshaded, with high irradiation mostly, and the space for development is quite considerable. The global potential capacity of offshore PV is about 4000GW, and the overall potential capacity is very huge.

### 1.1 Offshore PV in China

Driven by the new energy policy of the Chinese government, China's coastal provinces have actively responded to the goal of realizing "Carbon Peaking and Carbon Neutrality Goals", and have successively focused on the development of Offshore PV. The main problems are: the power consumption in coastal areas is large, and the development of solar farm is limited by land resources (centralized power stations involve land, and distributed photovoltaic contributions are insufficient); Coastal provinces and cities are with rich marine resources, and the collaborative development of Offshore PV and wind power can effectively optimize investment costs (submarine cables, power transformation facilities, etc.); Offshore PV can also be combined with aquaculture, which can improve the overall investment return; The power generation efficiency of Offshore PV has a certain gain compared with that of onshore PV under the same lighting conditions. China's coastline is more than 18,000 kilometers, and the coastal beach area is more than 15,000 square kilometers, of which the pile-based offshore PV can be installed in an area of more than 1,800 square kilometers, and the beach pile-based photovoltaic can be installed in an area of more than 2,000 square kilometers. In theory, China can install more than 100GW of offshore PV.

### 1.2 Offshore PV in other regions

The Asia-Pacific is another blue ocean region for the development of offshore PV. Especially in Southeast Asia, the region is densely populated, offshore photovoltaic has become one of the main development direction of its energy transition. From a theoretical point of view, the Asia-Pacific region, especially in Southeast Asia, can be installed offshore PV more than 50GW, the market prospect is broad.

Latin America also focuses on offshore PV. There are long coastlines in Latin America, the power consumption in coastal areas is huge, new energy development is limited by the constraints of land resources, offshore PV development can effectively solve the energy and consumption problems.

# 02

## Offshore PV classification and current challenges

### 2.1 Classification of offshore photovoltaics

As a new type of energy utilization and resource development mode, offshore photovoltaic power generation utilizes photovoltaic technology to set up power stations on the ocean, which is characterized by high power generation capacity, low land occupation, and easy integration with other industries. Compared with onshore PV, offshore PV has natural environmental advantages: the water surface is open and free of obstructions, and the sunlight is long and fully utilized (reflected light on the water surface), which can significantly increase the power generation capacity. Depending on the water depth and distance from the shore, offshore PV is mainly categorized into pile-fixed and floating types.

**Pile-based fixed photovoltaic power station**, is often applied to shallow water level, no site subsidence and other geologic hazards, water level changes smaller water surface sites, such as aquaculture ponds, salt farms draining ponds and so on. It is applicable to beach sites with a water depth of less than 8 meters, stable geology and small water level changes, and is currently the mainstream of offshore PV construction. This type of power station can adopt the construction mode of "fishery-photovoltaic complementarity", which is to utilize the marine resources of ponds in areas where aquaculture is concentrated to develop and build photovoltaic power generation projects. The mode of marine power generation and underwater aquaculture is adopted to realize the complementary development of multiple industries.

**Floating photovoltaic power plant (FPV)**, with the help of floating materials and anchoring systems to make photovoltaic modules, inverters and other power generation equipment floating on the sea surface for power generation, is suitable for the water area which depths are greater than 8 meters, the impact of typhoons are not big waters. In the long term, floating is expected to be the main form of offshore PV applications in the future. Floating photovoltaic power plants have a wider range of application scenarios and less environmental problems. From a global point of view, there are currently more than 60 countries actively promoting the construction of floating PV power stations at sea, of which more than 35 countries have 350 floating PV power stations. According to another study published by research organization GlobalIndustryAnalysts, the global deployment of floating PV installed capacity of 1.6GW in 2021, which is expected to grow to 4.8GW by 2026.

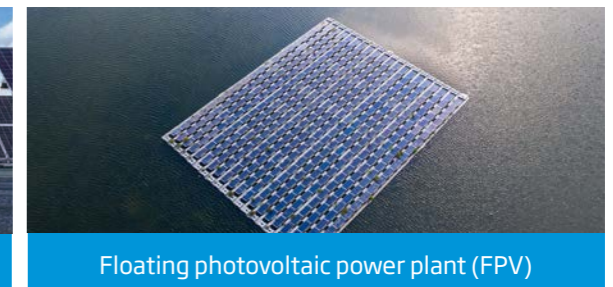

### 2.2 Main environmental challenges and failures of offshore PV

Compared with land, the environmental challenges faced by offshore PV modules are more complicated than those faced by onshore PV due to its special environment. The load on the floating body structure under wind, waves and currents increases dramatically, and the system safety faces serious challenges: the combined effect of the "three highs and three strengths" (high temperature, high humidity, high salt spray, strong gale, strong waves and strong precipitation) on the PV modules leads to a decrease in power generation efficiency and a shortened life span.

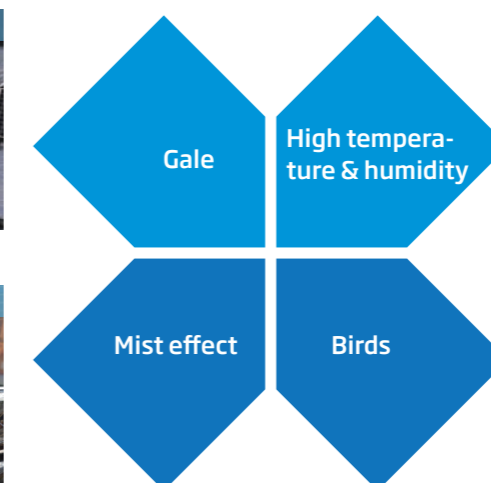
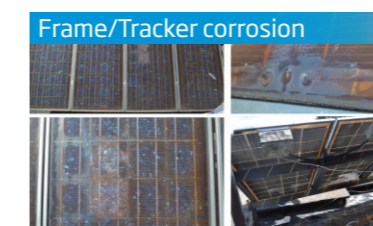

## Offshore photovoltaic module solutions

### 3.1 Module Solutions

According to the correlation study between salt spray deposition and distance from the coast in different seasons [1], in the range of distance from the coast up to 500m, salt spray deposition decreases with the increase of distance from the coast, and after more than 500m, it decreases slowly, when comes to more than 2000m, the salt spray deposition is in the range of  $60\text{mg}\cdot\text{m}^{-2}\cdot\text{d}^{-1}$ .

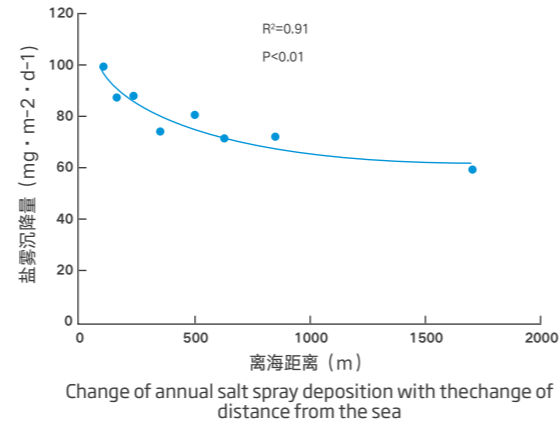

[1]侯梦莹,李芊芊,袁甜甜.南方滨海地区盐雾沉降的时空分布——以福建古雷半岛为例[J].生态学杂志,2019,38(8): 2524-2530

Based on this, Trina Solar provides two types of product solutions, floating PV module solution (FPV) and pile-based fixed PV module solution:

	Ocean	Coast	Land	
	Ocean area	Offshore area	500m	2000m
<b>Distance:</b>				
<b>Area:</b>	Ocean areas and some offshore areas	Offshore area	Within 500m from the coast	Onshore within 500m to 2km from the coast
<b>Installation:</b>	Floating PV	Pile-based fixed	Pile-based fixed	Conventional
<b>Module:</b>	Trina's dual glass products (recommend NEG21C.20, DEG21C.20, NEG19RC.20, DEG19RC.20) Dual glass + Dual Coated Front Panel Glass Frame AA15 IP68 Junction box and connectors + Dust Plugs	Trina's dual glass products (recommend NEG21C.20, DEG21C.20, NEG19RC.20, DEG19RC.20) Dual glass + Dual Coated Front Panel Glass Frame AA15 IP68 Junction box and connectors + Dust Plugs	Conventional Dual Glass Products	Conventional Products
<b>Other requirements:</b>	Antiseptic Bolt & Tracker	Antiseptic Bolt & Tracker	Standardized	Standardized

Definition	Offshore Distance	Module Solution	Bolt Requirements	Tracker Requirements
Floating photovoltaic power plant (FPV)	Ocean areas and some offshore areas	Dual Glass + Dual Coated Front Panel Glass + AA15 Frame + IP68 Junction Box & Connectors + Dust Plugs Recommended: double protection for connectors + waterproof cables	Antiseptic	Antiseptic
Pile-based fixed photovoltaic power station	Offshore areas and within 500m from the coast	Dual Glass + Dual Coated Front Panel Glass + AA15 Frame + IP68 Junction Box & Connector + Dust Plugs Recommended: double protection for connectors	Antiseptic	Antiseptic
Other locations	Onshore within 500m to 2km from the coast	Conventional Dual Glass Products	Standardized	Standardized
	≥ 2km from the coast	Conventional Single/Dual Glass Products	Standardized	Standardized

#### Connector dust plug:

It is designed to solve the problem of condensation vapor intrusion into the connector part during the installation of components in the morning and evening.



#### Connector double protection:

The connector is IP68 grade / salt spray S8, by adding the connector protective cover, which can play a double water-proof and salt spray role.



#### Double-coated glass:

The front glass can effectively protect the PV glass substrate from water vapor and salt spray corrosion by adding a layer of dense  $\text{SiO}_2$  layer, with better climate resistance.

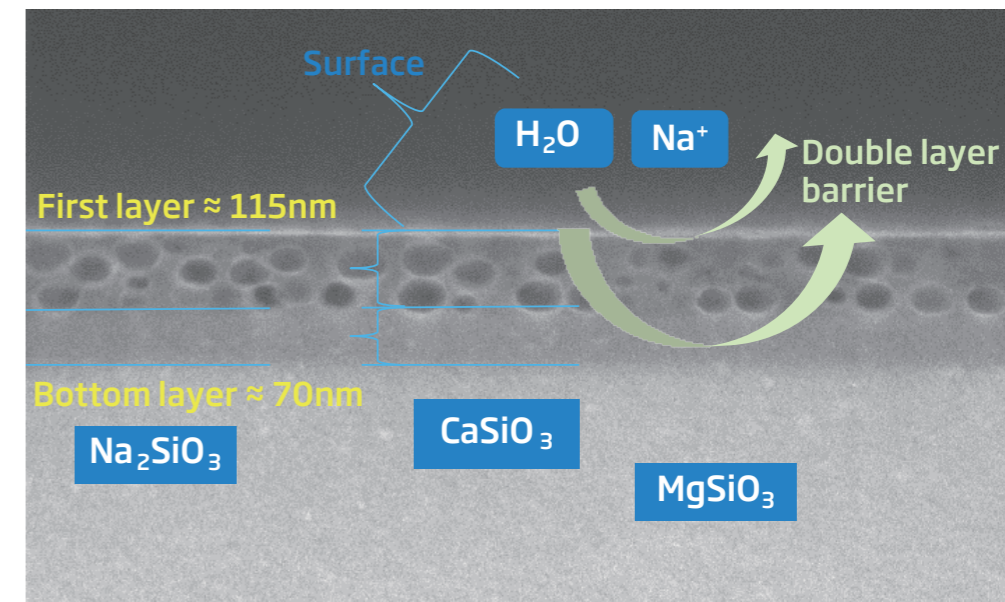

### 3.2 Offshore PV Module Certification

Trina's vertex series modules have been certified by TÜV Rheinland Offshore PV2 PfG 2930/02.23, which is the first offshore certificate and an important milestone for PV products in offshore applications.



### 3.3 Trina's 700W + offshore solution

In addition to dealing with the technical difficulties of reliability, offshore PV cost control is also extremely critical to a fishing and solar complementary project as an example for calculation: compared to the reference modules, the BOS cost of the 210-66 N-type module can save ¥0.03-0.06/w or more.

Products	Trina's N type	Reference N type A	Reference N type B
Size (mm)	2384*1303	2465*1134	2465*1134
Power (W)	680	610	610
Voc (V)	47.4	51.47	55.25
Isc (A)	18.18	15.01	14.11
Number of blocks of a single string component	29	26	24
Low-voltage electrical costs (¥/W)			
Inverter	0.0241	0.0242	0.0242
Convergence box (including construction)	0.0013	0.0017	0.0018
MC4 connector (including construction)	0.0015	0.0019	0.0020
Cables (including construction)	0.0247	0.0258	0.0264
Low Voltage DC Cable (including construction)	0.0687	0.1020	0.1162
Grounding wire (including construction)	0.0026	0.0029	0.0029
Bridge (including construction)	0.0062	0.0078	0.0085
Cable gutter (including construction)	0.0096	0.0094	0.0120
Inverter Installation	0.0005	0.0005	0.0005
Consider	0.1391	0.1761	0.1945
Difference	BL	0.0370	0.0554
Structural costs (Pile exposed 5.5m) (¥/W)			
Racking (including construction)	0.2605	0.2648	0.2541
Pile foundation (including construction)	0.2793	0.2701	0.2926
Consider	0.5398	0.5350	0.5468
Difference	BL	-0.0048	0.0070
land rent (¥/W)			
Consider	0.1375	0.1385	0.1382
Difference	BL	0.0010	0.0007
Cost of BOS (¥/W)			
Consider	0.8164	0.8495	0.8795
Cost differential of BOS (¥/W)			
Consider	BL	0.0331	0.0631

First of all, Ocean is vast and unshaded compared to onshore projects, with high irradiation mostly, which is more suitable for the arrangement of long array bracket; secondly, due to the external sea water depth and waves, wind conditions are complex, and some areas also need to consider the impact of icing, so the fixed PV project pile foundation design is longer and the pile type is larger. Compared with onshore PV, its foundation materials and construction costs are much higher. In addition, because the marine environment requires high resistance to wind, corrosion, humidity and heat, and aging of materials, effectively reducing the amount of materials brings better economic benefits than land-based PV projects.

Trina's N-type Vertex 700W+ module, with its low Voc and higher power output, has a more obvious BOS cost advantage in offshore applications.

### 3.4 Coastal and Offshore Considerations for Offshore PV Modules

#### 3.4.1 Bird droppings

There are many flying birds in the sea, birds stay for a long time and bird droppings will make the module produce hot spots, it is suggested to consider the solution from the following three aspects:

1. Using infrared interference to avoid birds approaching;
2. Using special frequency band acoustic wave interference to avoid birds approaching;
3. Regular cleaning by manual operation and maintenance.

### 3.4.2 Wave dissipation

Offshore PV needs to avoid wind and waves directly hitting the surface of the module, it is recommended that:

1. Pipe pile elevation, the lower edge of the module is higher than the highest wave in past 50 years;
2. Breakwaters reduce the impact of waves.

# 04

## Trina Solar's reliability enhancement tests related to Offshore PV

Offshore PV modules need to be toughened in terms of load, salt spray, PID, DH, etc. Trina Solar has collaborated with a third-party testing organization to carry out a series of toughened tests.

### 4.1 Mechanical loads:



**Uneven snow load**

Withstands 2.8 metres of uneven snow loads



**Extreme low temperature**

-40 °C high reliability

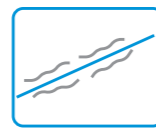

**Dynamic load fatigue**

+1500Pa @20000 times dynamic cycle

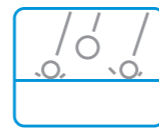

**Hail test**

Past 35mm hail test

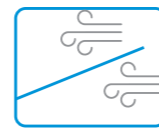

**wind tunnel test**

Passed category 17 hurricane test

Trina Vertex modules have passed five extreme and rigorous load tests, which can maintain highly reliable load performance under extreme climatic conditions.

### Analysis of modules damage principle under high winds:

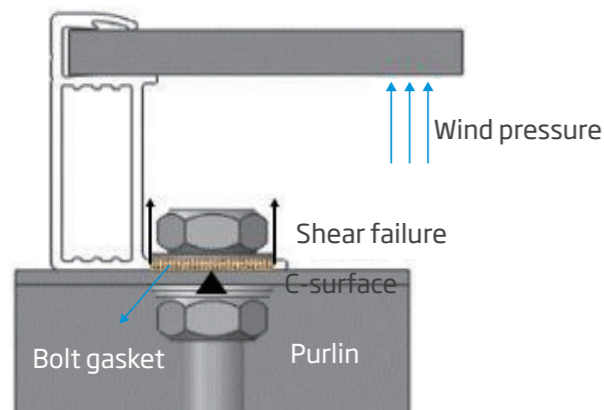

For torn edges and loose bolts brought about by windy in the marine environment, enhancements were made in the following two aspects:

- 1) Increase the wall thickness of the modules bezel to reduce the force arm, select appropriate bolt spacers, and install them in strict accordance with the user's manual to ensure the torque.

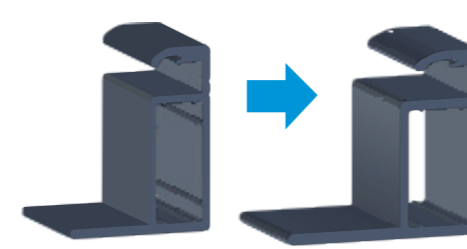

Groups	B Height (mm)	C Width (mm)	C Thickness (mm)	C d-length (mm)
210-66	33	28.5	1.8	18.1

- 2) It is recommended to use anti-loosening bolt mounting to avoid torque attenuation and installation strength degradation caused by frequent vibration of the components under strong winds.

Program	Principle	Picture	Vibration time (S)	Residual axial force/initial axial force
Metal Locking	Overfitting at the threads to increase friction		240	98.00%

### Strong wind test:

- 1) Strong wind tunnel experiments with beam screw mounting, 210 large-size modules can withstand wind speeds of over 60m/s.

Wind rating	12	13	14	15	16	17
Name	Cyclones	Cyclones	Cyclones	Cyclones	Cyclones	Cyclones
air velocity (m/s)	32.7-36.9	37.0-41.4	41.5-46.1	46.2-50.9	51.0-56.0	56.1-61.2

- 2) According to the "reliability test requirements of PV modules under the application scenario of flexible stent", we designed large-size modules with flexible stent simulation excitation experiment: vibration frequency of 6Hz, amplitude of 10mm and 20mm, simulated wind pressure of 1.0kN/m<sup>2</sup>, the total number of vibrations reaches 2.3 million times of excitation test, and vibration times can be enveloped in 80% of the regions in the country. After 2.3 million times of simulated excitation, the module did not show obvious hidden crack phenomenon. There are no cracks, breaks, tears, etc. in the aluminum alloy frame of the module, while the prestressing cable structure, connectors and bolts of the module are intact.

3) Zhejiang Jiaxing Outdoor empirical Base: In 2022, after Typhoon Meihua landed, the 210 large-size components were intact.



#### 4.2 High temperature and humidity:

- 1) Rigorous DH test: Supreme double-glass module passed DH3000 test, EL is no abnormality, power attenuation is only 1.31%;
- 2) Rigorous PID test: Supreme double-glass module passed the humid-heat-water immersion PID test and was corrected by Arrhenius equation, and the degradation is no more than 3% within 30 years of offshore life cycle.

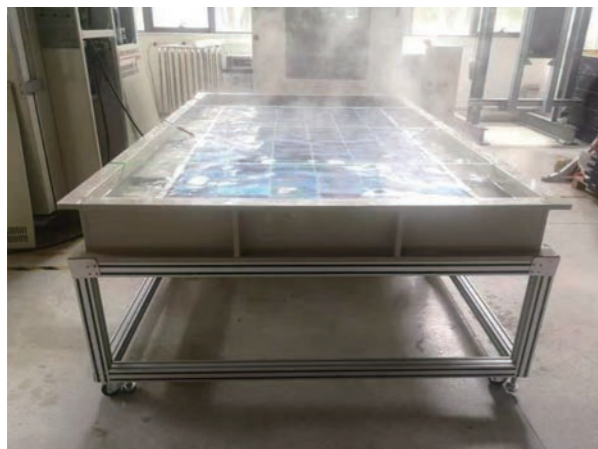

PID test device  
(60°C、75°C、85°C, 3.5% saline soak PID)

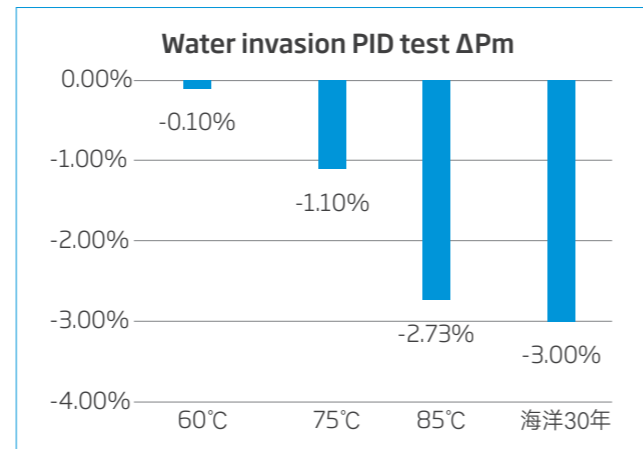

65°C、75°C、85°C, 3.5% saline soak  
PID power degradation

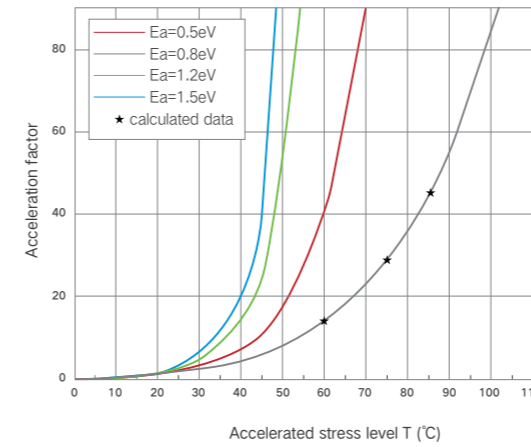

$$AF(T, RH) = \left( \frac{RH_{\text{试验}}}{RH_{\text{实际}}} \right)^n \exp \left[ \frac{E_a}{k} \left( \frac{1}{T_{\text{实际}}} - \frac{1}{T_{\text{试验}}} \right) \right]$$

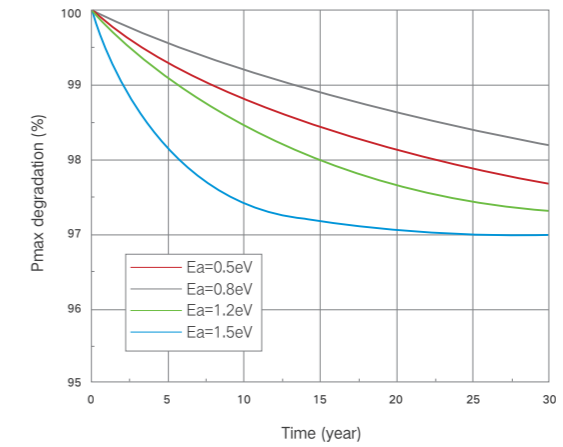

$$P(t; temp; H) = P_{\infty} * \{1 - \exp(-RU * AF(T; RH) * t)\}$$

#### 4.3 Salt-spray corrosion:

To simulate the ability of PV modules to withstand coastal corrosive environments, international certification bodies use the IEC 61701-2011 & IEC 60068-2-52 standards for testing.

Table A.1 - Simplified guidance for determining corrosivity classifications according to ISO 9223 and test methods correlating to one-year corrosivity based on mass loss of steel coupons				
Corrosivity classification of module location	Location characteristics		One-year mass loss range(g/m <sup>2</sup> ) of bare steel coupons	60068-2-52 test method achieving similar one-year corrosivity
	Distance from saltwater(km)	Percentage Time of Wetness (ToW)		
C1 (testing per this document not necessary)	--	--	<10	none
C2 (testing per this document not necessary)	≥10	<25%	10-200	2,3
C3	≥10 2 to 10	≥25% <25%	200-400	4(14 days)
C4	2 to 10 <2	≥25% <25%	400-650	1(28 days) 5(28 days)
C5	<2	≥25%	600-1500	6(56 days)
CX	offshore	--	1500-5500	7(90 days) 8(70 days)

According to IEC61701-2020 salt spray corrosion test for PV modules, the corrosion conditions CX for offshore environments can be referred to the test methods of Methods 7 and 8.

Refer to the following table for salt spray test methods:

**Table 1 - Test cycles for test methods 1 to 8**

Test methods	Details of the cycle	Recommended number of cycles
Test method 1	<p>One cycle = 7 days</p> <p>In the case of manual handling, the transition time (max. 2h) should be included in the humid condition period of 6 days and 22 h .</p>	4 cycles (28 days)
Test method 2	<p>One cycle = 1 days</p> <p>In the case of manual handling, the transition time (max. 2h) should be included in the humid condition period of 22 h .</p>	3 cycles (3 days)
Test method 3	<p>Repeat 4 times</p> <p>One cycle = 7 days</p>	1 cycles (7 days)
Test method 4		2 cycles (14 days)
Test method 5		4 cycles (28 days)
Test method 6		8 cycles (56 days)
Test method 7	<p>One cycle = 8 h</p>	3,6,12,30,45,60, 90,150,180 cycles
Test method 8	<p>The transition times (time allowed to reach the temperature and relative humidity specified for a condition after changing to that condition) are within 30 min or between 30 min and 60 min from salt mist to dry condition, within 15 min or between 15 min and 30 min from dry condition to humid condition and within 30 min from humid condition to salt mist. Those transition times shall be included in next condition period.</p>	(1,2,4,10,15,20, 30,50,60 days)
<p>NOTE The ± tolerances given for temperature and relative humidity are the allowable fluctuations which are defined as the positive and negative deviations from the setting of the sensor at the operational control set point during equilibrium conditions. This does not mean that the set value can vary by plus/minus the amount indicated from the given value.</p>		

In order to simulate better the corrosion in the actual installation situation, the screw mounting method is used for the alternating salt spray S8 test. Due to the different activities of the aluminum alloy frame, mounting bolts and bracket metal, the connection position is prone to electrochemical reaction (sacrificial anode, protective cathode) resulting in embrittlement of the mounting holes, reduction of the mounting strength, and corrosion of the bracket to different degrees. Similarly, outdoors, the same electrochemical corrosion problem appeared in a fishery-photovoltaic power station after 8 years of operation.

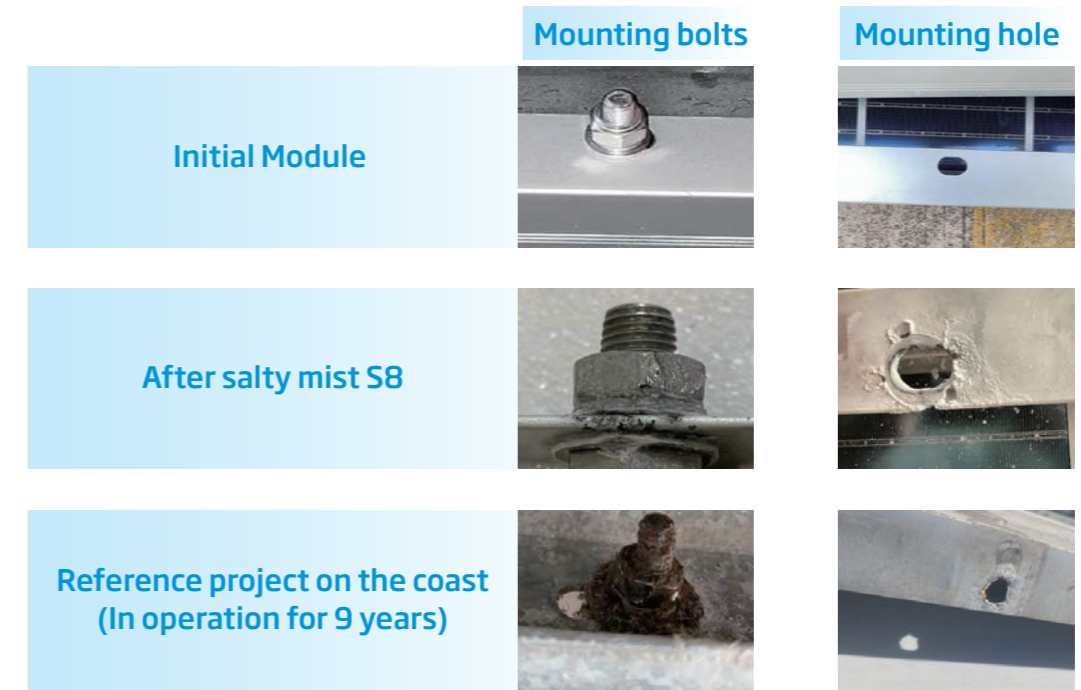

Offshore PV has problems electrochemical corrosion of the frame-bolt connection position, and solve the problem from the following two aspects:

- 1) PV module frame oxide film thickness  $\geq 15\mu\text{m}$ , PV bracket galvanized layer thickening, mounting bolts with special insulating coating treatment, to avoid metal ions with the help of seawater migration caused by galvanic coupling corrosion;
- 2) After the installation is completed, the connection position is protected by spraying paint and so on.



# 05

## Trina Solar offshore PV case

📍 Yantai CIMC Offshore Floating Platform Empirical Project



📍 Taishan Haiyan 100MV Offshore Project



# 06

## Trends and Prospects of Offshore PV

### ▶ The Offshore PV space type and functionality will be further enhanced.

Global offshore is growing rapidly, and the growth in market demand has contributed to further reductions in the cost of electricity, and cost reductions are conducive to larger-scale penetration, forming a closed loop of growth. Future Offshore PV will be combined with aquaculture industry, hydrogen production and other industries to maximize the value. In addition, floating photovoltaic does not require complex and time-consuming infrastructure, which is beneficial to the rapid construction of the project, and will become the mainstream of seamount photovoltaic.

### ▶ Offshore “wind and solar power plant”.

Offshore floating photovoltaic can use idle sea space in offshore wind farms; offshore photovoltaic can reuse cables and transmission line equipment with offshore wind power; wind and solar can be effectively realized as complementary from the perspective of resources; offshore photovoltaic can share the piling foundation of offshore wind power and provide more convenient mooring and installation methods; and it can greatly enhance the degree of intensive and economical utilization of resources and increase the output and economic benefit of power generation farms.

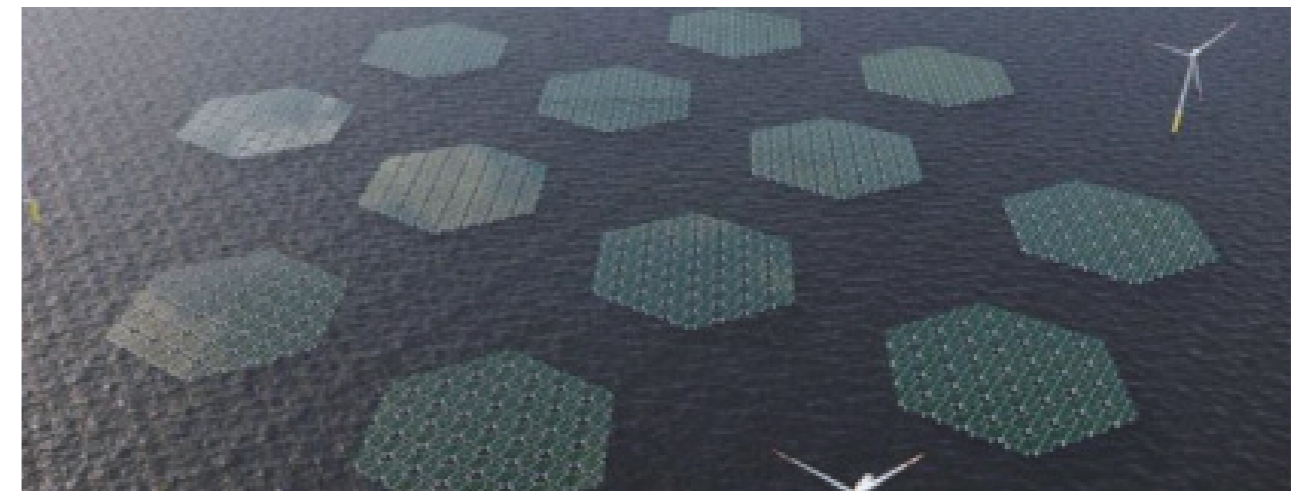

### ▶ The offshore energy island.

The offshore energy island is regarded as the future way of large-scale use of renewable energy, which refers to the inheritance of multiple forms of renewable energy utilization on artificially constructed large-scale offshore fixed or floating structures to form complementary, large-scale power generation advantages. The development of a variety of offshore energy integration on the basis of marine wind and solar complementary, compound use of marine natural resources, the formation of complementary advantages, optimize spatial configuration, improve resource utilization efficiency, promote intensive and economical use of the sea, and promote the integration of technology innovation in the field of marine clean energy.

### ▶ Offshore PV and hydrogen, ammonia production.

Integrate offshore photovoltaic power generation with hydrogen and ammonia production equipment in close proximity to save transmission system costs.